

Gallium Nitride 28V, 18W RF Power Transistor

Built using the SIGANTIC® NRF1 process - A proprietary GaN-on-Silicon technology

FEATURES

- Optimized for CW, Pulsed, WiMAX, and other applications from 3000 - 6000MHz
- 18W P3dB CW Power
- 25W P3dB peak envelope power
- 1.7W linear power @ 2% EVM for single carrier OFDM, 10.3dB peak/average, 10.3dB @ 0.01% probability on CCDF, 10.5dB gain, 18% drain efficiency
- Characterized for operation up to 32V
- 100% RF tested
- Thermally enhanced industry standard package
- High reliability gold metallization process
- Lead-free and RoHS compliant
- Subject to EAR99 export control

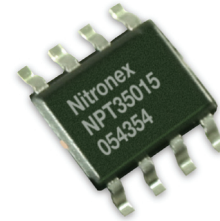

3000 – 6000 MHz
18 Watt, 28 Volt
GaN HEMT



Typical 2-Tone Performance: $V_{DS} = 28V$, $I_{DQ} = 200mA$, Frequency = 3500MHz, Tone spacing = 1MHz, $T_C = 25^\circ C$.
 Measured in Nitronex Test Fixture

Symbol	Parameter	Min	Typ	Max	Units
$P_{3dB,PEP}$	Peak Envelope Power at 3dB Compression	14	18	-	W
$P_{1dB,PEP}$	Peak Envelope Power at 1dB Compression	-	10	-	W
G_{SS}	Small Signal Gain	10	11	-	dB
η	Peak Drain Efficiency at $P_{OUT} = P_{3dB}$	43	48	-	%

RF Specifications (CW): $V_{DS} = 28V$, $I_{DQ} = 200mA$, Frequency = 3500MHz, $T_C = 25^\circ C$, Measured in Load Pull System

Symbol	Parameter	Typ	Units
P_{3dB}	Average Output Power at 3dB Gain Compression	18	W
$P_{3dB,Pulsed}$	Pulsed Output Power at 3dB Gain Compression	20	W
$P_{1dB,Pulsed}$	Pulsed Output Power at 1dB Gain Compression	15	W

Typical OFDM Performance: $V_{DS} = 28V$, $I_{DQ} = 200mA$, $P_{OUT,AVG} = 1.7W$, single carrier OFDM waveform 64-QAM 3/4, 8 burst, 20ms frame, 15ms frame data, 3.5MHz channel bandwidth. Peak/Avg = 10.3dB @ 0.01% probability on CCDF. Frequency = 3300 to 3800MHz. $T_C = 25^\circ C$. Measured in Load Pull System (Refer to Table 1 and Figure 1)

Symbol	Parameter	Typ	Units
G_P	Power Gain	10.5	dB
η	Drain Efficiency	18	%
EVM	Error Vector Magnitude	2.0	%
IRL	Input Return Loss	10	dB

NPT35015 Datasheet



DC Specifications: $T_C = 25^\circ\text{C}$

Symbol	Parameter	Min	Typ	Max	Units
Off Characteristics					
V_{BDS}	Drain-Source Breakdown Voltage ($V_{GS} = -8\text{V}$, $I_D = 8\text{mA}$)	100	-	-	V
I_{DLK}	Drain-Source Leakage Current ($V_{GS} = -8\text{V}$, $V_{DS} = 60\text{V}$)	-	1	3	mA
On Characteristics					
V_T	Gate Threshold Voltage ($V_{DS} = 28\text{V}$, $I_D = 8\text{mA}$)	-2.3	-1.8	-1.3	V
V_{GSQ}	Gate Quiescent Voltage ($V_{DS} = 28\text{V}$, $I_D = 200\text{mA}$)	-2.0	-1.5	-1.0	V
R_{ON}	On Resistance ($V_{GS} = 2\text{V}$, $I_D = 60\text{mA}$)	-	0.45	0.50	Ω
I_D	Drain Current ($V_{DS} = 7\text{V}$ pulsed, $300\mu\text{s}$ pulse width, 0.2% duty cycle, $V_{GS} = 2\text{V}$)	4.7	5.0	-	A

Absolute Maximum Ratings: Not simultaneous, $T_C = 25^\circ\text{C}$ unless otherwise noted

Symbol	Parameter	Max	Units
V_{DS}	Drain-Source Voltage	100	V
V_{GS}	Gate-Source Voltage	-10 to 3	V
P_T	Total Device Power Dissipation (Derated above 25°C)	28	W
θ_{JC}	Thermal Resistance (Junction-to-Case)	6.25	$^\circ\text{C}/\text{W}$
T_{STG}	Storage Temperature Range	-65 to 150	$^\circ\text{C}$
T_J	Operating Junction Temperature	200	$^\circ\text{C}$
HBM	Human Body Model ESD Rating (per JESD22-A114)	1A (>250V)	
MM	Machine Model ESD Rating (per JESD22-A115)	M1 (>50V)	

Table 1: Optimum Source and Load Impedances for OFDM Linearity, $V_{DS} = 28V$, $I_{DQ} = 200mA$

Frequency (MHz)	$Z_S (\Omega)$	$Z_L (\Omega)$	$P_{OUT} (W)$	Gain (dB)	Drain Efficiency (%)
3300 ¹	5.4 - j10.3	2.9 - j2.5	1.7	10.9	19
3400 ¹	5.0 - j10.7	2.9 - j2.6	1.8	11.0	22
3500 ¹	4.4 - j11.2	2.8 - j2.7	1.7	10.9	21
3600 ¹	4.0 - j12.5	2.8 - j3.3	1.7	10.9	20
3700 ¹	3.5 - j13.4	3.0 - j3.8	1.8	10.8	20
3800 ¹	3.5 - j14.6	3.2 - j4.2	1.8	10.7	20

Note 1: Single carrier OFDM waveform 64-QAM 3/4, 8 burst, 20ms frame, 15ms frame data, 3.5 MHz channel bandwidth.
Peak/Avg = 10.3dB @ 0.01% probability on CCDF, 2% EVM.

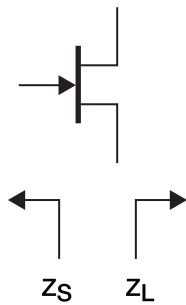

Z_S is the source impedance presented to the device.
 Z_L is the load impedance presented to the device.

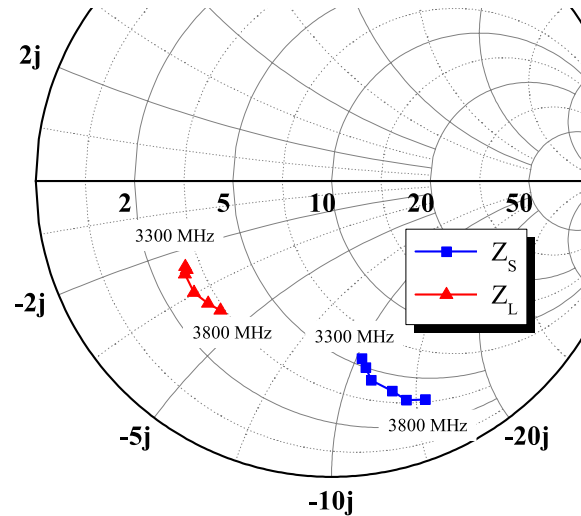

Figure 1 - Optimal Impedances for OFDM Linearity, $V_{DS} = 28V$, $I_{DQ} = 200mA$

Load-Pull Data, Reference Plane at Device Leads

$V_{DS}=28V$, $I_{DQ}=200mA$, $T_A=25^{\circ}C$ unless otherwise noted.

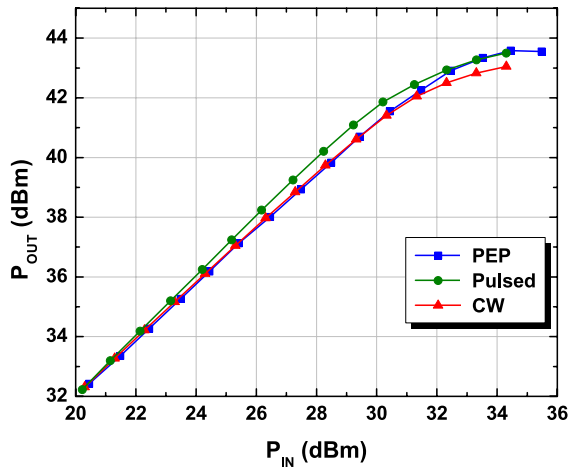

Figure 2 - CW, pulsed CW, and PEP, 3500MHz, Constant Impedance States

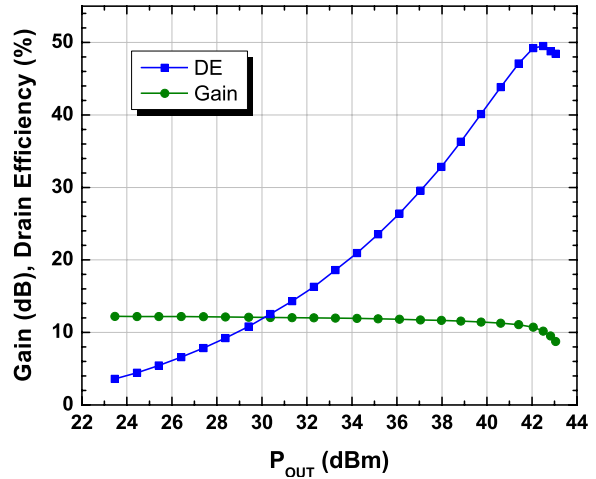

Figure 3 - CW Power Sweep, 3500MHz

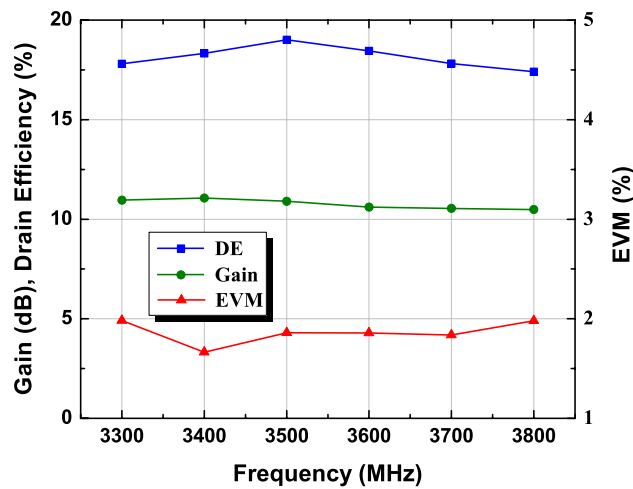

Figure 4 - Typical OFDM Performance $P_{OUT} = 1.5W$

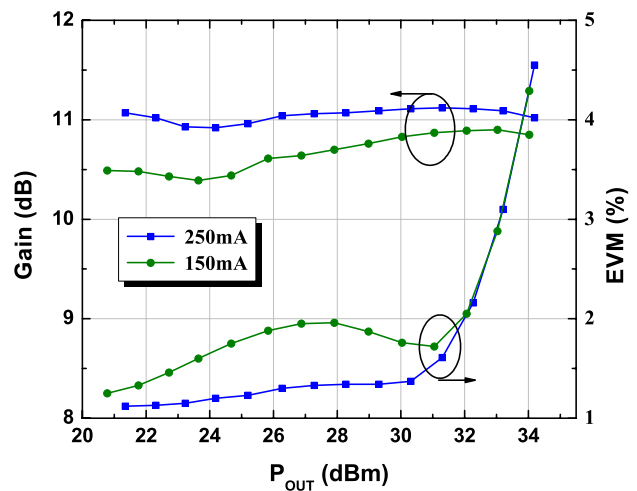

Figure 5 - Typical OFDM Performance at 3500MHz versus I_{DQ}

Load-Pull Data, Reference Plane at Device Leads

$V_{DS}=28V$, $I_{DQ}=200mA$, $T_A=25^{\circ}C$ unless otherwise noted.

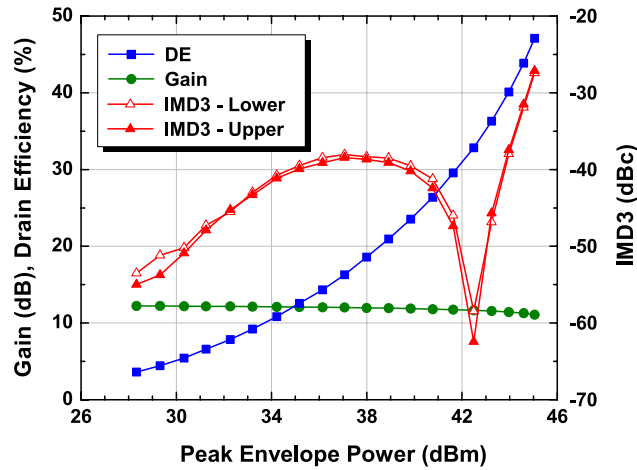

Figure 6 - Typical IMD3 Performance, 3500MHz

Typical Device Characteristics

$V_{DS}=28V$, $I_{DQ}=200mA$, $T_A=25^{\circ}C$ unless otherwise noted.

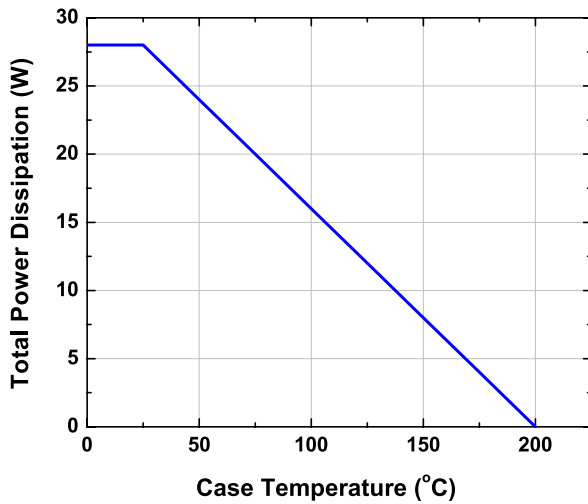

Figure 7 - Power Derating Curve

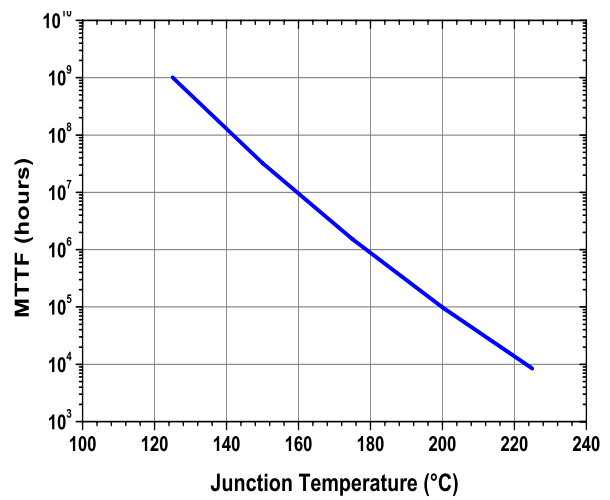

Figure 8 - MTTF of NRF1 Devices

AD-006 3400-3600MHz 1.7W Linear WiMAX Application Design

802.16e Single Carrier OFDM, 64-QAM 3/4, 8-burst, 20ms frame 100% filled, 3.5MHz channel bandwidth, PAR=10.3dB @ 0.01% CCDF
 Detailed design information and data available at www.nitronex.com

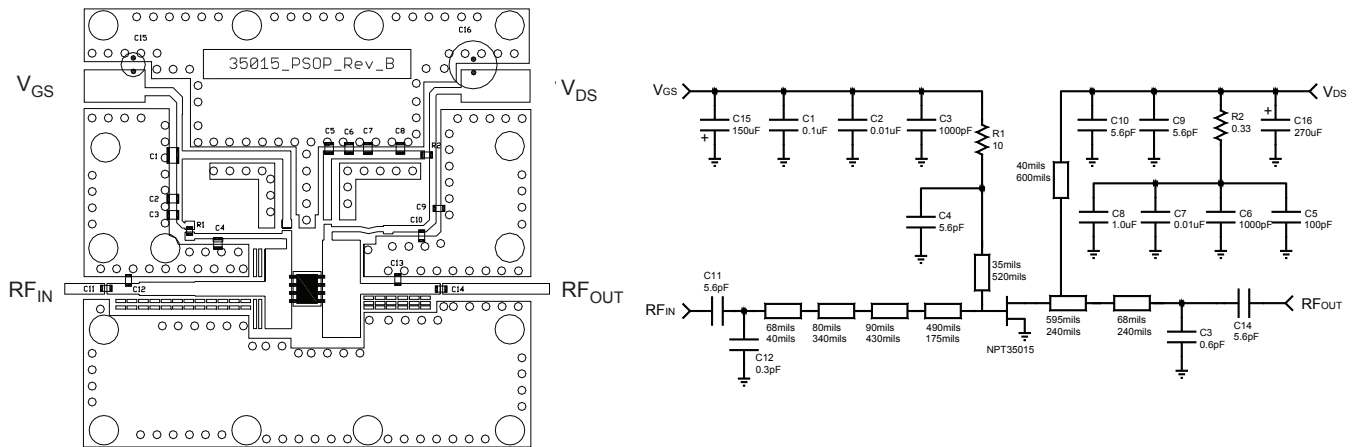

Figure 9 - AD-006 Demonstration Board and Schematic

Table 2: AD-006 Demonstration Board Bill of Materials

Name	Value	Tolerance	Vendor	Vendor Number
C1	0.1uF	10%	Kemet	C1206C104K1RACTU
C2, C7	0.01uF	10%	AVX	12061C103KAT2A
C3, C6	1000pF	10%	Kemet	C0805C102K1RACTU
C5	100pF	10%	Kemet	C0805C101K1RACTU
C8	1.0uF	10%	Panasonic	ECJ-5YB2A105M
C4, C9, C10, C11, C14	5.6pF	+/- 0.1pF	ATC	ATC600F5R6B
C12	0.3pF	+/- 0.1pF	ATC	ATC600F0R3B
C13	0.6pF	+/- 0.1pF	ATC	ATC600F0R6B
C15	150uF	20%	Nichicon	UPW1C151MED
C16	270uF	20%	United Chemi-Con	ELXY630ELL271MK25S
R1	10 ohm	1%	Panasonic	ERJ-2RKF10R0X
R2	0.33 ohm	1%	Panasonic	ERJ-6RQFR33V
PA1	--	--	--	NPT35015D
Substrate			Rogers	R04350, t = 30mil $\epsilon_r = 3.5$

AD-006 3400-3600MHz 1.7W Linear WiMAX Application Design

802.16e Single Carrier OFDM, 64-QAM 3/4, 8-burst, 20ms frame 100% filled, 3.5MHz channel bandwidth, PAR=10.3dB @ 0.01% CCDF
 Detailed design information and data available at www.nitronex.com

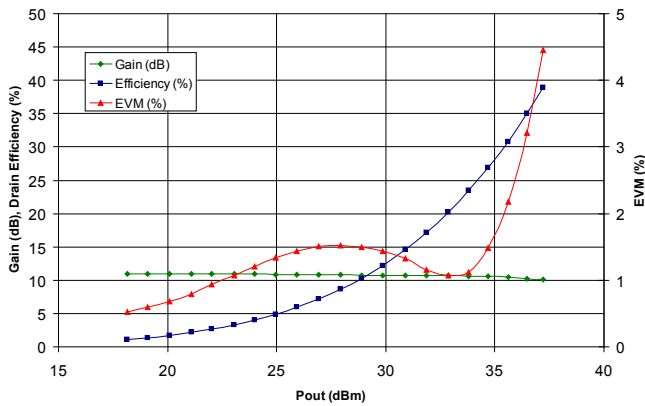

Figure 10 - Gain, Efficiency, EVM at 3400MHz

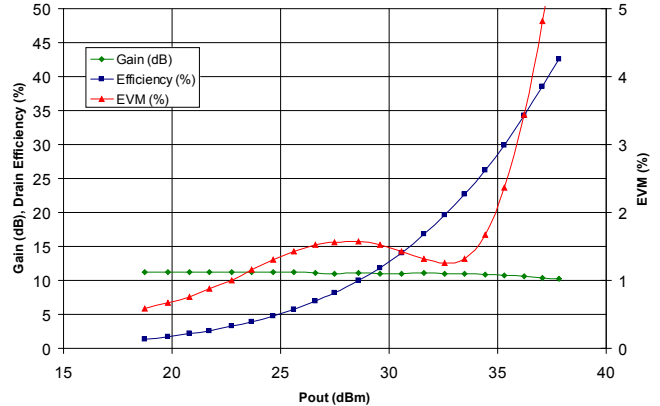

Figure 11 - Gain, Efficiency, EVM at 3500MHz

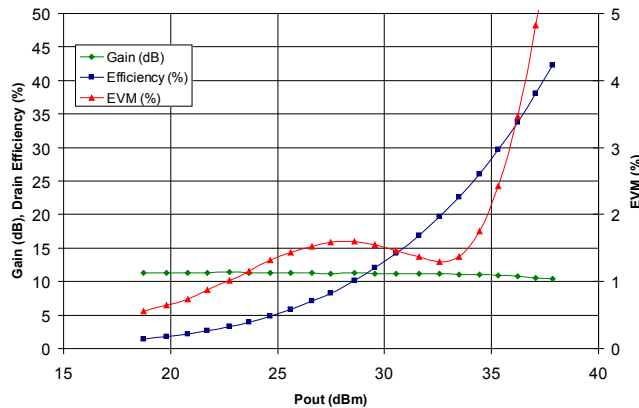

Figure 12 - Gain, Efficiency, EVM at 3600MHz

AD-006 3400-3600MHz 1.7W Linear WiMAX Application Design

802.16e Single Carrier OFDM, 64-QAM 3/4, 8-burst, 20ms frame 100% filled, 3.5MHz channel bandwidth, PAR=10.3dB @ 0.01% CCDF
 Detailed design information and data available at www.nitronex.com

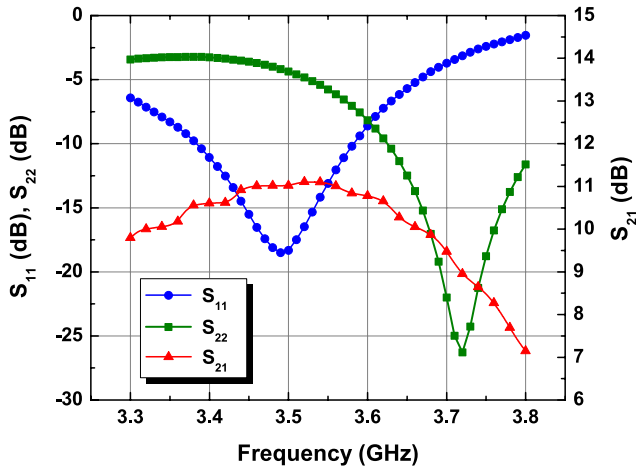

Figure 14 - Typical S_{11} and S_{21}

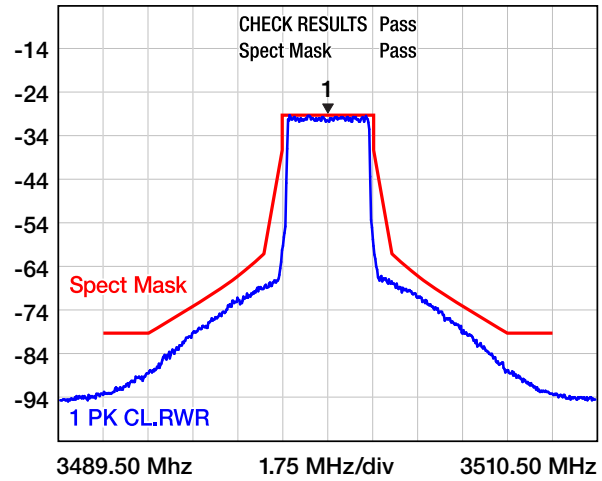

Figure 13 - ETSI Mask Compliance in Nitronex Demonstration Board at 3500MHz and $P_{OUT} = 1.5W$

NPT35015 Datasheet



Ordering Information

Part Number	Order Multiple	Description
NPT35015DT	97	Tube; NPT35015 in D (PSOP2) Package
NPT35015DR	1500	Tape and Reel; NPT35015 in D (PSOP2) Package

1: To find a Nitronex contact in your area, visit our website at <http://www.nitronex.com>

Figure 15 - D Package Dimensions and Pinout

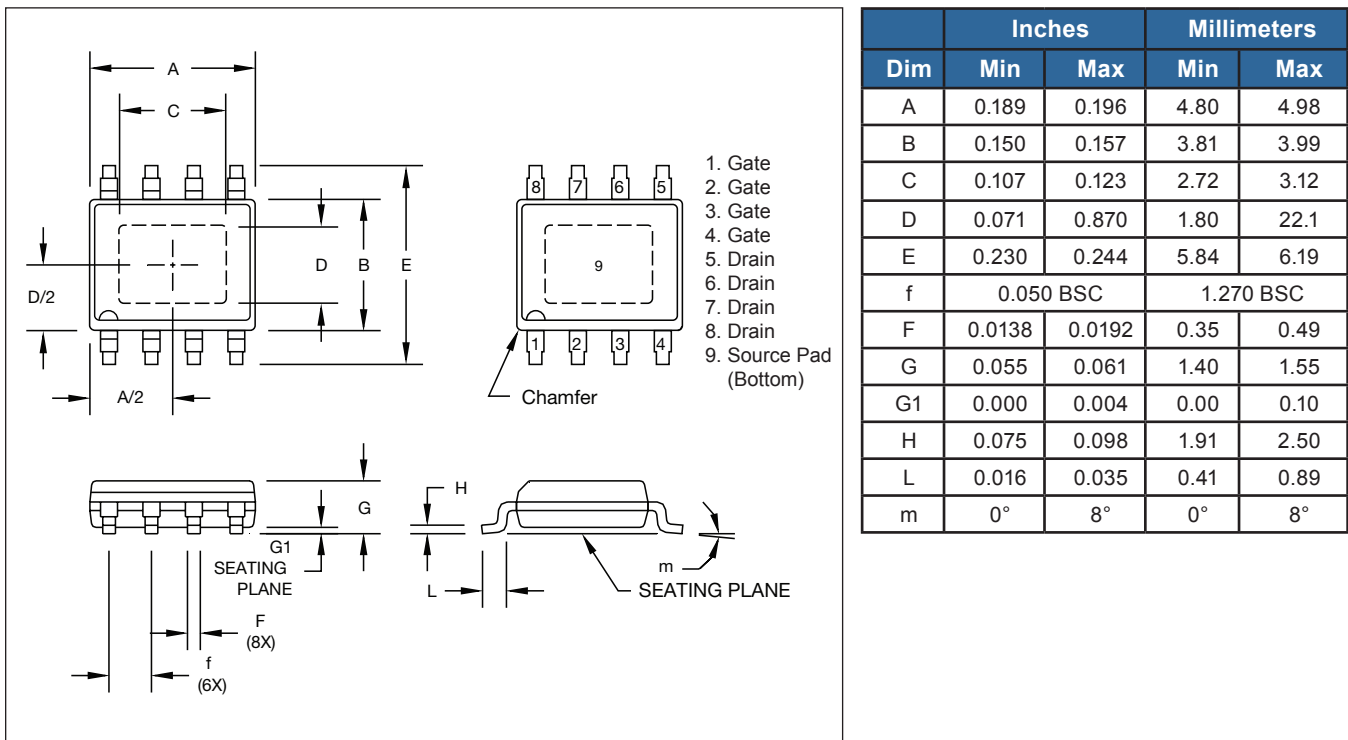
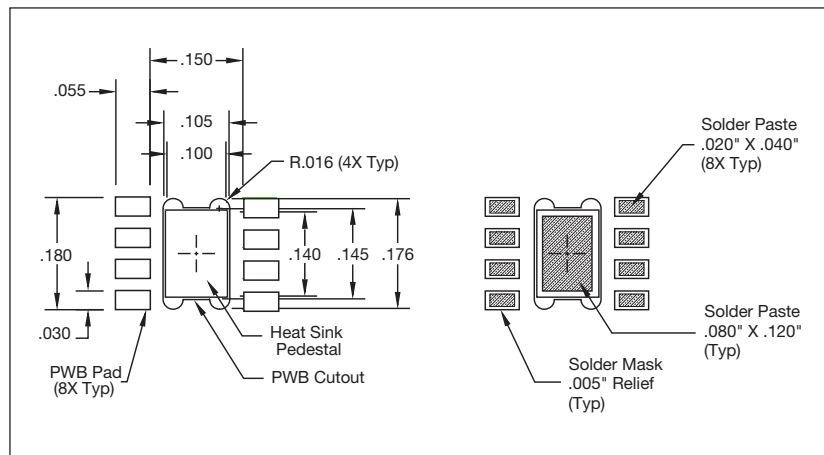

Figure 16 - Mounting Footprint



Nitronex Corporation

2305 Presidential Drive
Durham, NC 27703 USA
+1.919.807.9100 (telephone)
+1.919.807.9200 (fax)
info@nitronex.com
www.nitronex.com

Additional Information

**This part is lead-free and is compliant with the RoHS directive
(Restrictions on the Use of Certain Hazardous Substances in Electrical and Electronic Equipment).**

Important Notice

Nitronex Corporation reserves the right to make corrections, modifications, enhancements, improvements and other changes to its products and services at any time and to discontinue any product or service without notice. Customers should obtain the latest relevant information before placing orders and should verify that such information is current and complete. All products are sold subject to Nitronex terms and conditions of sale supplied at the time of order acknowledgment. The latest information from Nitronex can be found either by calling Nitronex at 1-919-807-9100 or visiting our website at www.nitronex.com.

Nitronex warrants performance of its packaged semiconductor or die to the specifications applicable at the time of sale in accordance with Nitronex standard warranty. Testing and other quality control techniques are used to the extent Nitronex deems necessary to support the warranty. Except where mandated by government requirements, testing of all parameters of each product is not necessarily performed.

Nitronex assumes no liability for applications assistance or customer product design. Customers are responsible for their product and applications using Nitronex semiconductor products or services. To minimize the risks associated with customer products and applications, customers should provide adequate design and operating safeguards.

Nitronex does not warrant or represent that any license, either express or implied, is granted under any Nitronex patent right, copyright, mask work right, or other Nitronex intellectual property right relating to any combination, machine or process in which Nitronex products or services are used.

Reproduction of information in Nitronex data sheets is permitted if and only if said reproduction does not alter any of the information and is accompanied by all associated warranties, conditions, limitations and notices. Any alteration of the contained information invalidates all warranties and Nitronex is not responsible or liable for any such statements.

Nitronex products are not intended or authorized for use in life support systems, including but not limited to surgical implants into the body or any other application intended to support or sustain life. Should Buyer purchase or use Nitronex Corporation products for any such unintended or unauthorized application, Buyer shall indemnify and hold Nitronex Corporation, its officers, employees, subsidiaries, affiliates, distributors, and its successors harmless against all claims, costs, damages, and expenses, and reasonable attorney fees arising out of, directly or indirectly, any claim of personal injury or death associated with such unintended or unauthorized use, notwithstanding if such claim alleges that Nitronex was negligent regarding the design or manufacture of said products.

Nitronex and the Nitronex logo are registered trademarks of Nitronex Corporation.
All other product or service names are the property of their respective owners.
©Nitronex Corporation 2007. All rights reserved.