

NPT25240 Product Preview

Gallium Nitride 48V, 240W High Electron Mobility Transistor

Built using the SIGANTIC® NRF1 process - A proprietary GaN-on-Si technology.

FEATURES

- Designed for WiMAX applications at frequencies from 2.3 – 2.7 GHz.
- Typical OFDM Performance for $V_{DS}=48$ Volts, $I_{DQ}=1200$ mA, center frequency 2.6 GHz. Single carrier OFDM waveform 64-QAM 3/4, 8 burst, 7 MHz channel bandwidth. Peak / Avg. = 10.3 dB @ 0.01% probability on CCDF:
 - Avg. Output Power: ≥ 33 Watts
 - EVM: $\leq 2.5\%$
 - Drain Efficiency: $\geq 22\%$
 - Gain: ≥ 15 dB
- ≥ 240 Watts Typical P_{3dB} @ 2.6 GHz
- 100% Tested under OFDM waveform
- Thermally enhanced industry standard package
- High reliability gold metallization process
- Lead-free and RoHS compliant
- Breakdown voltage $\geq 200V$

NPT25240

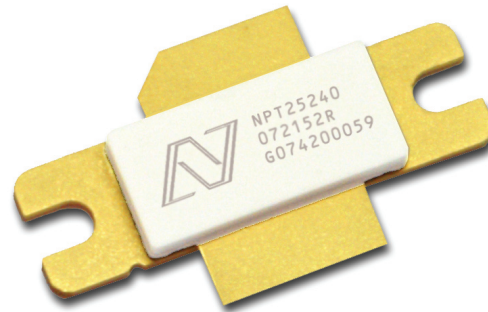

2.3 – 2.7 GHz , 240 Watt, 48 Volt
GaN HEMT



Maximum Operating Conditions - Not simultaneous. ($T=25 \pm 3^\circ C$ unless otherwise noted).

Rating	Symbol	Value	Units
Drain-Source Voltage	V_{DS}	150	V
Gate-Source Voltage	V_{GS}	-10, +3	V
Total Device Power Dissipation (Derated above 25° C)	P_D	219	W
Thermal Resistance (Junction-to-Case)	θ_{JC}	0.8	$^\circ C/W$
Storage Temperature Range	T_{STG}	-65 to +150	$^\circ C$
Operating Junction Temperature	T_J	200	$^\circ C$

ESD Sensitivity

ESD Model	Class
Human Body Model	1C (>1000 Volts)
Machine Model	M3 (>200 Volts)

NPT25240 Product Preview



PA Notional Lineup

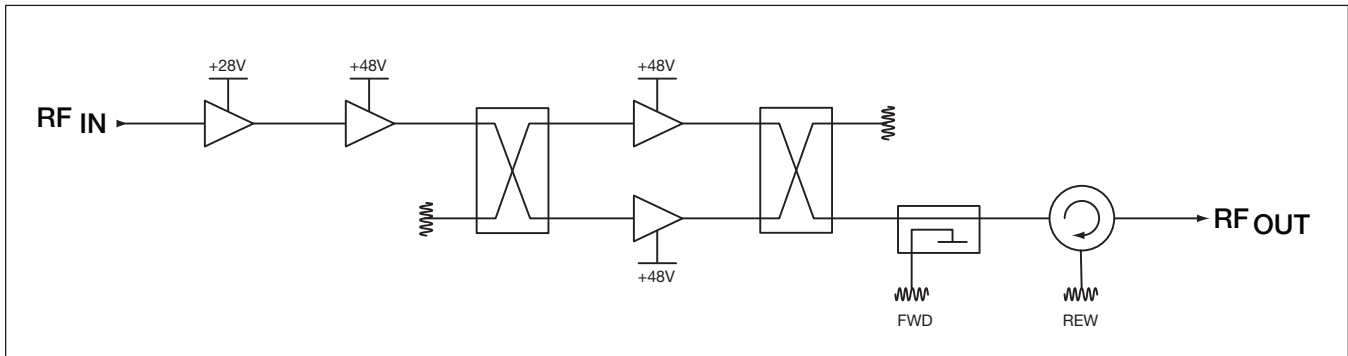

Notional Lineup Performance for WiMAX

Parameter	Units	Pre-Driver	Driver Stage	Output Stage	PA Overall	Units	Parameter
Device		NPTB00004	NPTB00080	2X NPT25240			Device
Stage Pin	dBm	5.7	18.7	30.2	5.7	dBm	Stage Pin
Gain	dB	14	15	15	40.8	dB	Gain
Stage Pout	dBm	19.7	33.7	45.2	46.5	dBm	Stage Pout
	W	0.1	2.4	33.4	45.0	W	
Psat	dBm	36.0	49.0	53.8	55.1	dBm	Psat
	W	4.0	80.0	240	324	W	
EVM	%	<1.5	<1.5	2.5	2.5	%	EVM
Efficiency	%	9.2	11.2	24.2	15.1	%	Efficiency
Pdc	W	1.0	21.1	138	297	W	Pdc

Notional Lineup Performance for W-CDMA

Parameter	Units	Pre-Driver	Driver Stage	Output Stage	PA Overall	Units	Parameter
Device		NPTB00004	NPTB00080	2X NPT25240			Device
Stage Pin	dBm	8.0	21.0	32.5	8.0	dBm	Stage Pin
Gain	dB	14	15	15	40.8	dB	Gain
Stage Pout	dBm	22.0	36.0	47.5	48.8	dBm	Stage Pout
	W	0.2	3.9	55.6	75.0	W	
Psat	dBm	36.0	49.0	53.8	55.1	dBm	Psat
	W	4.0	80.0	240	324	W	
ACPR	%	<-50	<-45	-38	<-35	dBc	ACPR
Efficiency	%	11.9	14.4	31.3	19.5	%	Efficiency
Pdc	W	1.3	27.3	178	384	W	Pdc